

Fibertech **INC**



Creating Environmentally
Responsible Solutions

Bulk Containers

4 Series

These containers are one of the most durable and versatile material handling containers in the industry.



- 4-Way entry replaceable pallet bolted/welded on a high quality one-piece design.
- Reinforced rim
- Flat bottom with smooth flat interior surfaces for easy product flow and cleaning
- Rounded interior corners to alleviate product collection points.
- Ergonomically placed handles for easier container movement and reduction or elimination of vacuum by nesting.
- Nestable and stackable with lid.

***F-SP** is simply a Free Standing Pallet that is compatible with the 4Series containers.

MODEL	OUTSIDE DIMENSIONS	CUBIC FEET	GALLON CAPACITY	WEIGHT
F436	48" x 44" x 36"	30 cu/ft	225gal	140lbs
F438	48" x 44" x 38"	32 cu/ft	240gal	145lbs
F442	48" x 44" x 42"	37 cu/ft	275gal	150lbs
F445	48" x 44" x 45"	40 cu/ft	300gal	155lbs
F448	48" x 44" x 48"	42 cu/ft	325gal	170lbs
F456	48" x 44" x 56"	50 cu/ft	375gal	180lbs
F-4 Bolt-On PALLET	39" x 43" x 6"			45lbs
F-4 Bolt-On PALLET	39" x 43" x 6"			55lbs
F-SP PALLET	43" x 47" x 9"			55lbs

2 Series

Bulk containers with 2-Way accessibility featuring the latest in design to enhance quality and durability while maximizing the cost savings associated with the reusable containers.



- High quality one-piece design
- Reinforced rim
- Channeled bottom, smooth interior surfaces for easy product flow and cleaning.
- Rounded interior corners to alleviate product collection points.
- Unique angled leg design that helps prevent forklift damage by allowing the fork tines to deflect off the leg instead of breaking or cutting the container.
- Ergonomically placed handles for easier container movement and reduction or elimination of vacuum by nesting.
- Nestable and stackable with lid.

MODEL	OUTSIDE DIMENSIONS	CUBIC FEET	GALLON CAPACITY	WEIGHT
F233	41" x 41" x 33"	29 cu/ft	218gal	80lbs
F236	47" x 43" x 36"	34 cu/ft	255gal	100lbs
F245	47" x 43" x 45"	42 cu/ft	310gal	110lbs
F251	43" x 43" x 51"	44 cu/ft	330gal	120lbs

Lockers

Plastic Lockers

Our plastic lockers are maintenance-free and are a great alternative to metal lockers.



- Individually molded unit.
- Standard drain hole for ease of cleaning.
- Flat or sloped tops, available in three sizes.
- Sold as individual units for design and purchase flexibility.

MODEL	SHAPE	DIMENSIONS	WEIGHT	HOOKS	SHELF
12" Locker	Flat-Top	12" x 12" x 15"	6lbs.	N/A	N/A
12" Locker	Slope-Top	24.25" x 12" x 15"	8lbs.	N/A	N/A
18" Locker	Flat-Top	18" x 12" x 15"	9lbs.	N/A	N/A
18" Locker	Slope-Top	30.5" x 12" x 15"	11lbs.	N/A	N/A
36" Locker	Flat-Top	36" x 12" x 15"	15lbs	Yes	Optional
36" Locker	Slope-Top	48.5" x 12" x 15"	18lbs	Yes	Optional

Plastic Pallets

Our plastic pallets have been designed to reduce or eliminate the need for wood pallets and offer a cost-effective solution where strength, durability, washing ability, and contamination reduction are a necessity.

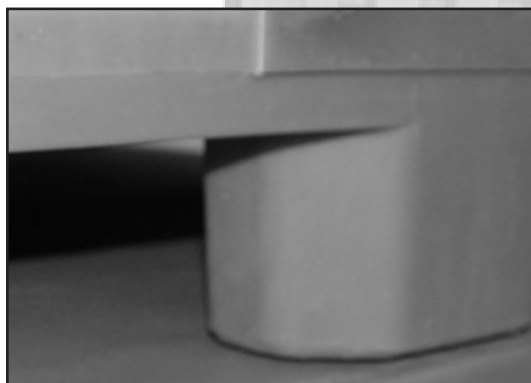

- Smooth top deck
- Unique angled leg design
- Optional 3/8" high lip
- USDA/FDA approved and 100% recyclable.

MODEL	OUTSIDE DIMENSIONS	CAPACITY	WEIGHT
NP4048-45	40" x 48" x 6"	2,000 lbs. - 2,500lbs.	45lbs.
NP4048-50	40" x 48" x 6"	2,500 lbs. - 3,000lbs.	50lbs.
NP4048-55	40" x 48" x 6"	3,000 lbs. - 3,500lbs.	55lbs.

RC38

This multipurpose collection cart is one of the most durable recycling carts in the industry.

- Nestable for efficient transport
- 5" rigid casters and 4" hard rubber swivel casters
- Reinforced rim
- Optional Forklift Pockets
- Optional Lid

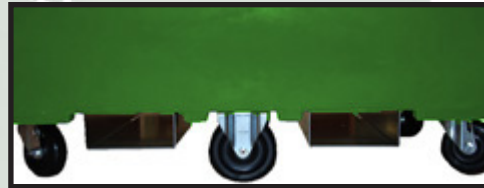

MODEL	DIMENSIONS	CAPACITY	BUSHELS	WEIGHT
RC38	43 3/4" x 28 3/4" x 40"	20 cu/ft	16	74lbs
RC38 LID	45 1/9" x 29 1/2" x 4 1/2"			17lbs

Utility Cart

The UC-Series are the next multi-purpose heavy-duty utility cart that supports a large variety of industry needs.

- Galvanized steel base.
- Nestable for storage and transport.
- Hard rubber casters.
- Optional Lid.



*UC12- 4" Casters

*UC16- 4" Casters

*UC20- 5" Casters

MODEL	DIMENSIONS	CAPACITY	BUSHELS	WEIGHT
UC-12	39 1/2" x 30" x 32"	15 cu/ft	12	67lbs
UC-16	43" x 32" x 34"	20 cu/ft	16	83lbs
UC-20	55 1/2" x 35 1/2" x 35"	25 cu/ft	20	103lbs

Caster Carts

Fibertech Inc. has engineered a custom caster configuration frame for our 4 Series container. This frame is designed for forklift entries that also allow the container to rotate. By adding casters to this stainless steel framed bulk container it now has the ability to be rolled for accessibility.



MODEL	OUTSIDE DIMENSIONS	CUBIC FEET	GALLON CAPACITY	WEIGHT
F436 SSF	48" x 44" x 39"	30 cu/ft	225gal	159lbs
F438 SSF	48" x 44" x 41"	32 cu/ft	240gal	164lbs
F442 SSF	48" x 44" x 45"	37 cu/ft	275gal	169lbs
F445 SSF	48" x 44" x 48"	40 cu/ft	300gal	174lbs
F448 SSF	48" x 44" x 51"	42 cu/ft	325gal	189lbs

Caster Bins

We bolt flat steel plates across the channeled bottom of the 2 Series combo bins and casters are attached to allow the plastic bulk bins the ability to be rolled for better handling.



MODEL	OUTSIDE DIMENSIONS	CUBIC FEET	GALLON CAPACITY	WEIGHT
F233 CB	41" x 41" x 40"	29 cu/ft	218gal	117lbs
F236 CB	47" x 43" x 43"	34 cu/ft	255gal	139lbs
F245 CB	47" x 43" x 52"	42 cu/ft	310gal	149lbs
F251 CB	43" x 43" x 58"	44 cu/ft	330gal	159lbs

Free Flow Containers

The Fibertech Free Flow 445 container is a single-wall, one-piece construction with welded-on pallet and no collection points. The container promotes free product flow with its contoured corners and smooth flat interior bottom. NO metal hardware makes this container ideal for food processors.



MODEL	OUTSIDE DIMENSIONS	CUBIC FEET	GALLON CAPACITY	WEIGHT
FF445	48" x 41" x 45"	36 cu/ft	270gal	145lbs
FF4- LID	43" x 51"			36lbs

DOT Container

Fibertech Inc. has created a unique DOT shipping container. Single-wall, one-piece design with bolted on pallet, made of linear low density polyethylene resin which produces a stronger finished product. The certified DOT Container meets critical hazardous material shipping standards featuring a sealable lid and security fastening closures making it ideal for the transport industry.

* 11H2 CERTIFIED



MODEL	DIMENSIONS	CU./FT. GALLON CAPACITY	WEIGHT
DOT	48" x 44" x 36"	30 cu/ft 225gal	122lbs
DOT-R	48" x 44" x 36"	30 cu/ft 225gal	128lbs
DOT LID			26lbs

Rotatable Container

The Rotatable Container is simply our 4 Series Bulk Container with engineered one-inch solid aluminum rods to make it rotatable. This bulk container design pairs one of the most durable bulk containers in the industry with the ability for secure tilting and dumping with a standard forklift 180 degree rotator.

*Weights vary
with 2 & 3 bar
configuration



MODEL	DIMENSIONS	CU./FT. GALLON CAPACITY	WEIGHT
F436-R	48" x 44" x 36"	30 cu/ft 225gal	146lbs
F438-R	48" x 44" x 38"	32 cu/ft 240gal	151lbs
F442-R	48" x 44" x 42"	37 cu/ft 275gal	156lbs
F445-R	48" x 44" x 45"	40 cu/ft 300gal	161lbs
F448-R	48" x 44" x 48"	42 cu/ft 325gal	175lbs

Container Lids

Add a dustcover lid to prevent product contamination or a stacking lid for the ability to stack.

MODEL	DIMENSIONS	STACKING WEIGHT	DUSTCOVER WEIGHT
F4 LID	51" x 47"	36lbs	26lbs
F233 LID	42 1/2" x 42 1/2"	35lbs	25lbs
F236 LID	48 3/4" x 44 3/4"	35lbs	25lbs
F245 LID	48 3/4" x 44 3/4"	35lbs	25lbs
F251 LID	44" x 44"	35lbs	25lbs



Welded Seam

A welded seam is used as support to the attachment of the bolted-on pallet and to keep foreign matter from getting between the pallet and the container.

Steel Forklift Pockets

By attaching galvanized steel forklift pockets to the bottom of our industrial carts it is now forklift accessible and rotatable.

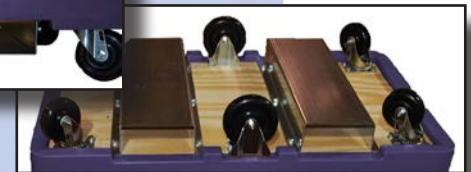

Custom Height Applications

In some cases specific heights are required; our plastic bulk containers can be cut down to meet the size need.

Custom Colored Plastic Containers

Custom colors are available in quantities of 50 or more and require an additional up charge of \$50.00. Custom colors or color matching can be done with a provided color sample, or specific Pantone color. Some colors may require quantities higher than 50 units. (Note: On-screen colors not representative of container colors – please request color swatches)

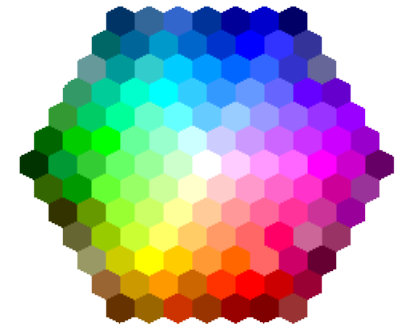

Repair

Fibertech Inc. plastic repair services offer extended life for your plastic container investment. Our complete and economical repair services make it easy to keep your bulk material handling equipment in peak condition. Our expertise in plastic manufacturing is applied in every container we repair.

- **Food Processing Combo Bins**
- **FDA/USDA Bulk Containers**
- **Pet Food Totes**
- **Agriculture Center Flow Containers**
- **Tanks:** water, storage, livestock
- **Corn Snouts**



Recycling

Fibertech views scrap as another raw material. The plastic recycling division was created for this very reason; the virgin scrap from molded product is ground up, pulverized and reused. Not only is this a responsible way to divert scrap from landfills, it provides a steady source of economical material for molding non-compliance products. We have the advantage of knowing that all our regrind is 2nd generation plastic since we are the recycler of the material. There are no risks of contamination or blends of unknown materials because we control every aspect of its collection and reuse.



Custom Rotational

In addition to the products that we sell, Fibertech, Inc. also offers custom rotational molding services to create the parts and products that you need to make your vision a reality. Our custom molding services are best suited for large products that need to be crafted from a heavy, durable material. Due to its adaptability, rotational molding can also be an excellent option for manufacturers and entrepreneurs that need unique parts and products.

- Our experienced team can help engineer the product, build a customized mold, and make the idea a reality.
- At Fibertech, we also assist individuals and businesses that already have a mold. We can use the existing mold with our equipment to produce the desired product or part.
- We can help your company create a new mold in order to create your existing product in a more durable form. Plastic is a common economical replacement for wood and metal parts and products that will stand the test of time.

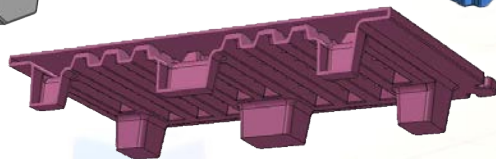
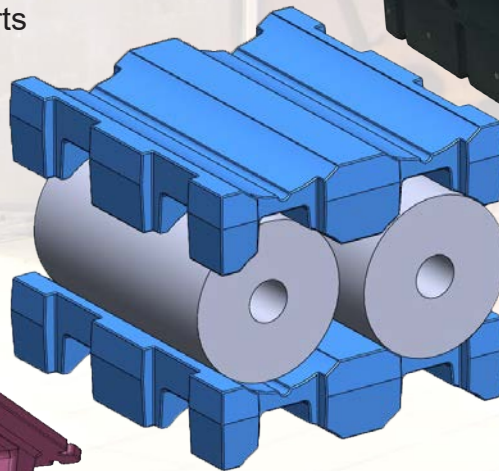
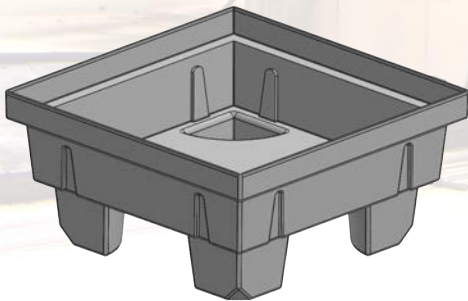
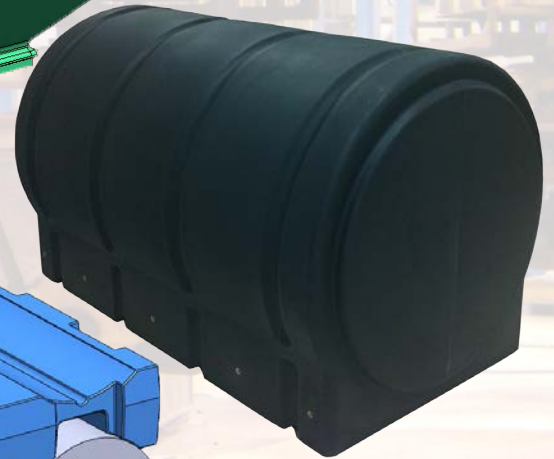
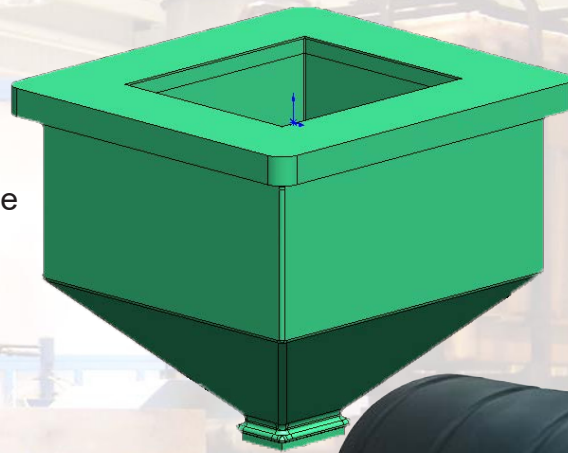

Color

Available in a choice of 15 Standard colors to color coordinate or brand your containers with company colors. Colors do not crack chip or fade. Color selection is available in virgin plastic material only; recycled plastic material comes in black only. To request actual color chips samples, call 800.304.4600. Please note that colors may vary depending on container size.



**Fibertech
Blue**



Royal Blue



Dolphin Blue



**Emerald
Green**



Forest Green



Safety Yellow



Safety Orange

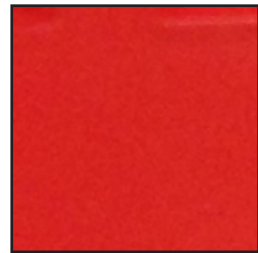

Fire Red



Brown



Tan



**Suede
Leather**



Malted Milk



**Natural
Translucent**

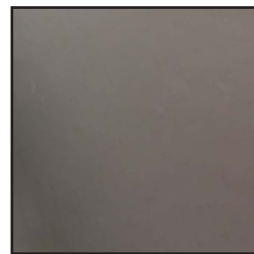

**Battleship
Gray**

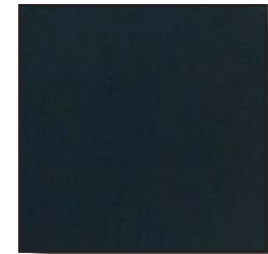

Black

Custom colors are available in quantities of 50 or more and require an additional up charge of \$50.00. Custom colors or color matching can be done with a provided color sample, or specific Pantone color. Some colors may require quantities higher than 50 units. (Note: Printed colors not representative of actual finished container colors – please request color swatches)



Fibertech INC



11744 Blue Bell Rd. Elberfeld IN 47613

www.fibertechinc.net

800-304-4600