

RHINO MANHOLES by

FIBERTECH **FPD**
PLASTICS



Applications

Landfill Applications

Leachate attacks concrete and metal because of its acidic nature; it is most common in landfill applications. The chemical resistant plastic manholes are not affected by leachate. As backfill is added to a landfill, the loads can increase and material will shift. The durability and strength of the rotationally molded polyethylene plastic manholes are the perfect solution for this application.

Chemical Plants

Plastic manholes manufactured with polyethylene are corrosion and abrasion resistant and therefore work well for many industrial and chemical applications. Plants with corrosive chemicals in their underground pipes benefit from the chemical resistant material and the versatility of design in the plastic manholes.

Stormwater Collection System

Plastic manholes are used on stormwater sewer lines for the convenience of holding rainwater. This system provides access and observation of the stormwater collection and flow. Sizes of these plastic manholes will vary in height according to the depth of the storm sewer.



Cones

Center Cone

The Concentric Cone is typically used in a catch basin application to allow water or other materials to drop straight down into the manhole. The molded-in steps are staggered from top to bottom for easier access.

Molded-in cut marks at the top of the cone allows for versatility in height and installation options on site.

- 48" Diameter
- 24" or 28" Neck Diameter

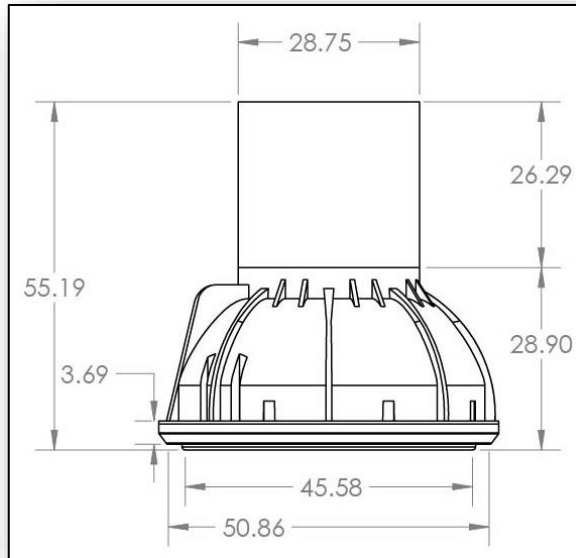

MODEL	BODY DIAMETER	NECK DIAMETER	OVERALL HEIGHT	DESCRIPTION	WALL
CC-4828	48"	28"	48"	CENTER CONE 48" TALL	0.5
CC-3628	48"	28"	36"	CENTER CONE 36" TALL	0.5
CC-3624	48"	24"	36"	CENTER CONE 24" NECK REDUCER	0.5

Offset Cone

An Eccentric Cone is ideal for sewer and stormwater applications. With the cone being offset this allows ease of climbing in and out. The molded-in steps are staggered from top to bottom for easier access. The different neck diameters and heights allows for versatility in installation options and can be cut on site.

- 48" Diameter
- 24" or 28" Neck Diameter

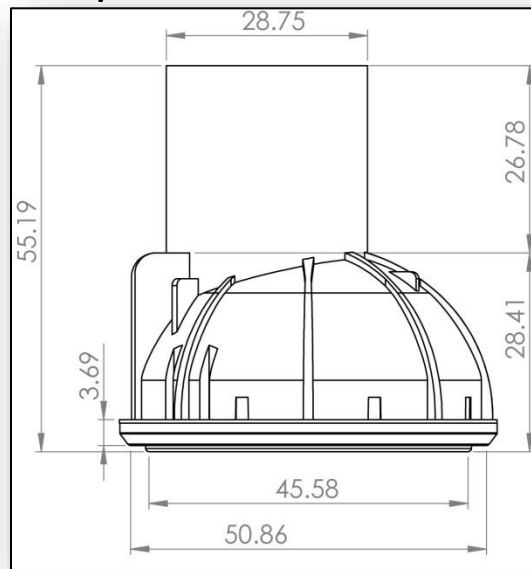

MODEL	BODY DIAMETER	NECK DIAMETER	OVERALL HEIGHT	DESCRIPTION	WALL
OC-4828	48"	28"	48"	OFFSET CENTER CONE 48" TALL	0.5
OC-3628	48"	28"	36"	OFFSET CONE 36" TALL	0.5
OC-3624	48"	24"	36"	OFFSET CONE 24" NECK REDUCER	0.5

Risers

The riser components are used to adjust the height of the base and cone components to grade. The joint is a tongue-and-groove design made watertight with a gasket seal. All risers have the molded-in staggered steps for ease of climbing in and out. The anti-flotation ring at the bottom of each riser, along with the vertical ribbing offer strength and anchors the structure to the backfill crushed rock material.

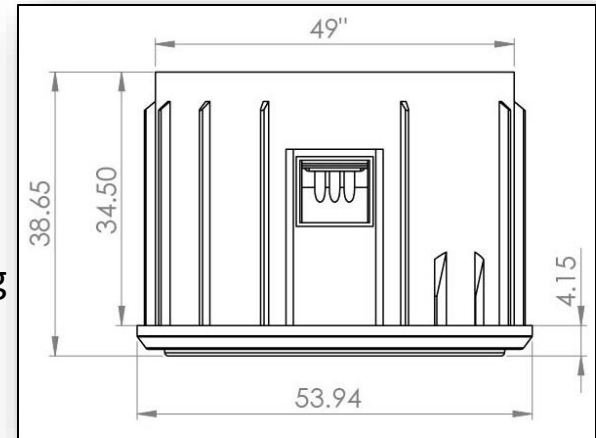
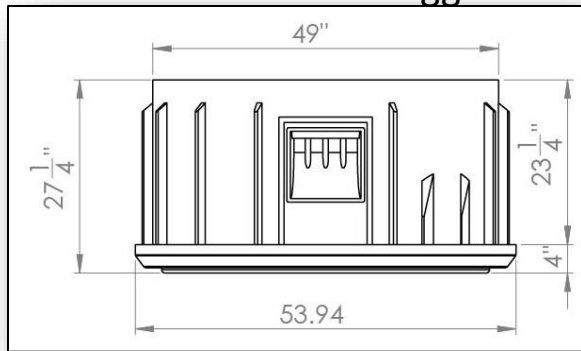

The anti-flotation ring at the bottom of each riser, along with the vertical ribbing offer strength and anchors the structure to the backfill crushed rock material.



MODEL	DIAMETER	HEIGHT	DESCRIPTION	WALL
R-24 RISER	48"	24"	24" TALL RISER	0.5
R-36 RISER	48"	36"	36" TALL RISER	0.5

Bases

Sanitary Bottom Base

Two different styles of hydraulically efficient bases eliminate turbulence and prevent debris build-up common to flat bottom concrete manholes. The Rhino Manhole by Fibertech storm sewer base has a contoured bottom which efficiently channels the flow from inlet to outlet. Five inlets, each with a 2% slope, are channeled to the outlet in the “Sanitary Sewer” manhole.

- 8" & 12" Extensions
- 42", 30", 22" High
- 6", 8" Diameter
- Outlets
- 6", 8", 10" Diameter
- Inlets
- Spout optional

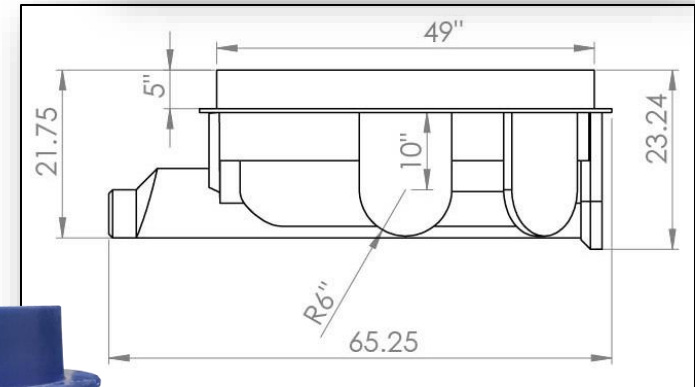
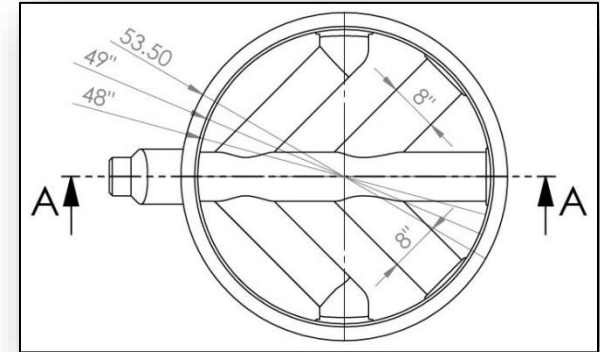

MODEL	DIAMETER	HEIGHT	DESCRIPTION	WALL
SB-22	48"	22"	SANITARY BOTTOM BASE WITH 6", 8" OUTLET	0.5
SB-30	48"	30"	22" SANITARY BOTTOM BASE WITH 8" EXTENSION, 6", 8" OUTLET	0.5
SB-42	48"	42"	22" SANITARY BOTTOM BASE WITH 8" + 12" EXTENSION, 6", 8" OUTLET	0.5

Large Sanitary Bottom Base

This base is by far the most versatile in applications and customizations. Inlet and outlet openings can be drilled or cut in the field to match existing pipe locations or to provide proper grade and alignment. The 5 standard molded-in inlet channels allow a 2% flow to the outlet.



- Spout optional
- 12" Extension
- 42", 30" High
- 8", 10", 12" Diameter Inlets
- 8", 10", 12" Diameter Outlets

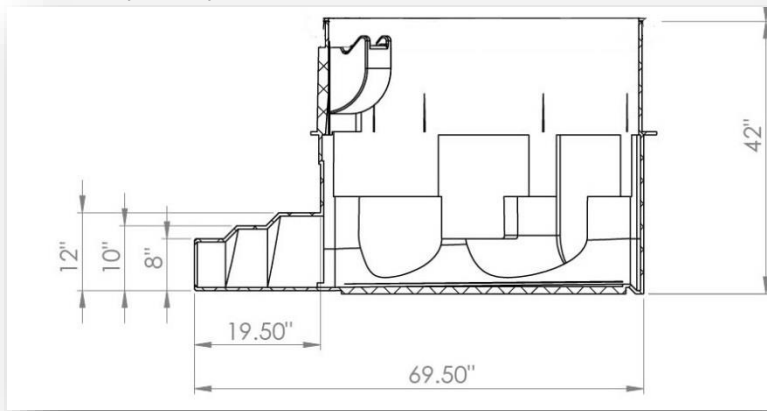

MODEL	DIAMETER	HEIGHT	DESCRIPTION	WALL
LSB-30	48"	30"	LARGE SANITARY BOTTOM BASE WITH 5 INLETS	0.5
LSB-42	48"	42"	30" LARGE SANITARY BOTTOM BASE WITH 12" EXTENSION, 5 INLETS	0.5

Round Bottom Base

This base is designed for storm drains. The height can be increased with a 12" extension offering a 48" high Round Bottom Base. Large pipes can be welded in with a plastic extrusion welder in the field.

- Accommodates varying pipe angles
- 48" Diameter
- 12" Extension
- 36", 48" High
- Can accommodate up to 32" pipe diameter.

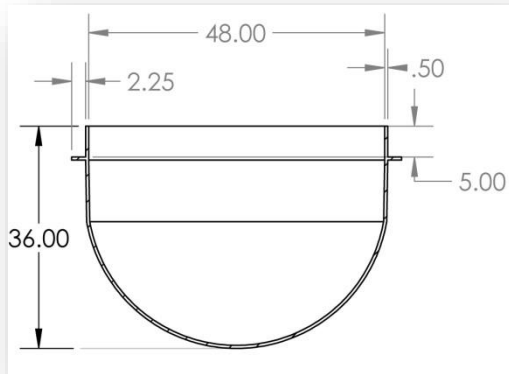

MODEL	DIAMETER	HEIGHT	DESCRIPTION	WALL
RB-36	48"	36"	ROUND BOTTOM BASE	0.5
RB-48	48"	48"	36" ROUND BOTTOM BASE WITH 12" EXTENSION	0.5

Gaskets

Manufactured from EPDM/CPE polymer these gaskets create a water tight seal between the manhole components.

- 28", 48" Diameter Rings
- Corrosion and Chemical Resistant



MODEL	DIAMETER	HEIGHT	WIDTH	DESCRIPTION
MH-28	28"	2-1/2"	1-1/64"	ETHYLENE PROPYLENE DIENE MONOMER RING
MH-48	48"	2-1/2"	1-1/64"	ETHYLENE PROPYLENE DIENE MONOMER RING

Lid

Featuring the latest in durability and design with a nominal 0.5" wall thickness, while maintaining an ease of installation. A concrete pad frame is used with road way applications and a gasket and frame grate or cover can be used for non-road way applications.

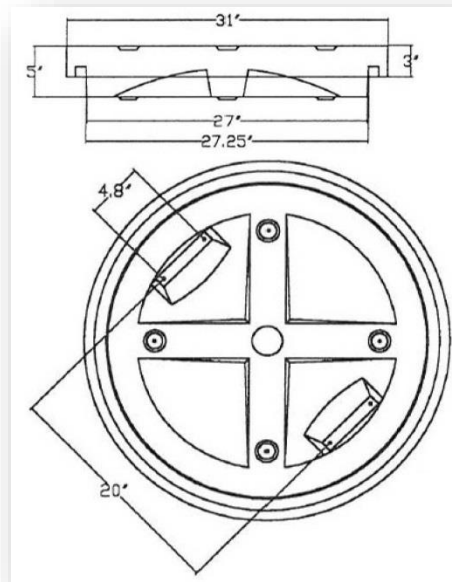

MODEL	DIAMETER	HEIGHT	DESCRIPTION	WALL
PL-28 LID	28"	3"	HOLLOW PLASTIC OR CONCRETE FILLED 0.5	0.5

Specifications

Materials

- RHINO MANHOLES by Fibertech are manufactured from 100% Certified High Density Polyethylene Resin.
- Chemical and Corrosion Resistant including H2S
- Impact Resistant, Tough and Durable
- Resin Density 0.942
- Melt Flow 2.0
- UV-12

Manufacturing

- RHINO MANHOLES by Fibertech are produced in the rotational molding process: base, riser, cone, and lid.
- Ease of interior access is provided with factory molded-in steps.
- Horizontal anchor rings are located along each joint and extend 2.5 inches from the outside diameter of the main body.
- Exterior vertical ribbing is designed in for additional structural support.

Requirements

All RHINO MANHOLES by Fibertech have walls that are a nominal 0.5 inches thick

Technical Standards

- | | | |
|----------------|---|---------------|
| • ASTM D-1693 | Environmental Stress Crack Resistance, Condition A | >743 |
| • ASTM D-1693 | Environmental Stress Crack Resistance, Condition B | >1000 |
| • ASTM D-790 B | Flexural Modulus, psi | 143,000 (986) |
| • ASTM D-790 B | Flexural Modulus, 1% Secant, psi | 107,000 (744) |
| • ASTM D-638 | Tensile Strength at Yield, psi | 3101 (21.4) |
| • ASTM D-638 | Tensile Elongation at Yield, % | 12 |
| • ASTM D-638 | Tensile Elongation at Break, % | 705 |
| • ASTM D-648 | Deflection Temperature Under Load @ 66 psi | 132 (55.3) |
| • ASTM F-648 | Deflection Temperature Under Load @ 264 psi | 107 (41.6) |
| • ASTM F-477 | Electrometric Seals for Joining Plastic Pipe | |
| • ASTM D-833 | Definition of terms relating to plastics | |
| • ASTM D-3350 | Specification for PE plastics molding and extrusions materials | |
| • ASTM D-2122 | Determining dimensions of thermo plastic pipe and fittings | |
| • AST F-412 | Definition of terms relating to plastic piping systems | |
| • ASTM D-2412 | External loading properties of plastic pipe by parallel plate loading | |

METHOD	SPECIFICATION	REQUIRED	OBTAINED
D-1056-B	COMPRESSION SET, % MAX, 22H @ RT, 50% DEFLECTION, 24H RECOVERY	25%	8.1
D-1056	COMPRESSION DEFLECTIONS @25% DEFLECTION	5-9PSI	8.4
	HEAT AGED 168H @158° MAX LOAD INCREASE TO DEFLECT 25%. D-573	25%	2.6
	SHRINKAGE, 50H @ 93°C	5% MAX	-3.4
D-1056	WATER ABSORPTION, MASS % CHANGE	+5%	1.04
D-1149	OZONE RESISTANCE 72H @ 38°C, 20% STRETCH, 100PPHM	NO CRACKS	NO CRACKS
	FLAMMABILITY, NOT ABLE TO SUPPORT COMBUSTION AFTER IGNITION	NO BURN	PASS
D-1056	OIL RESISTANCE 7 DAYS AT 23°C (73.4°F) CHANGE IN WEIGHT, FUEL B	150% MAX	94%

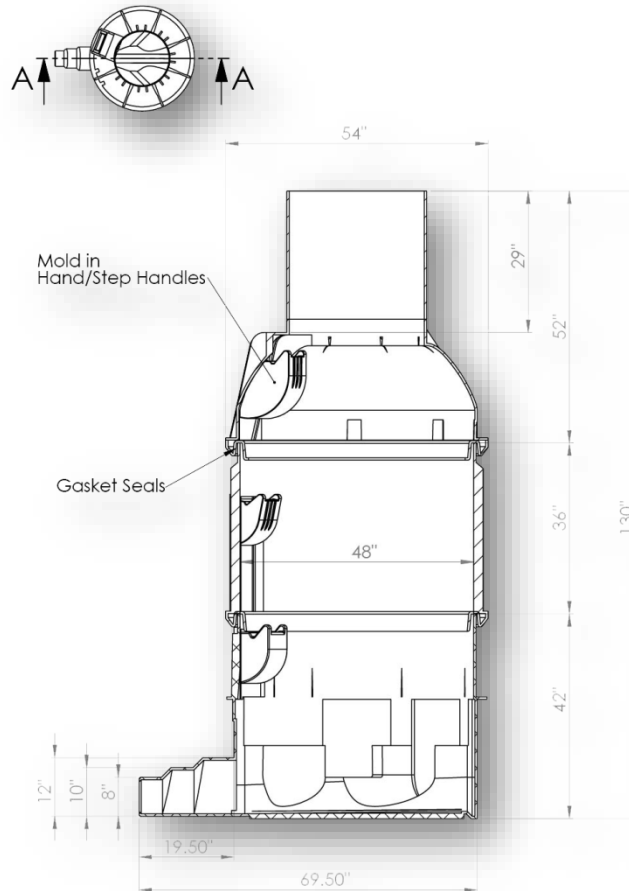



**11744 Blue Bell Rd.
Elberfeld IN 47613
800-304-4600
www.FibertechInc.net**